

YTER/L

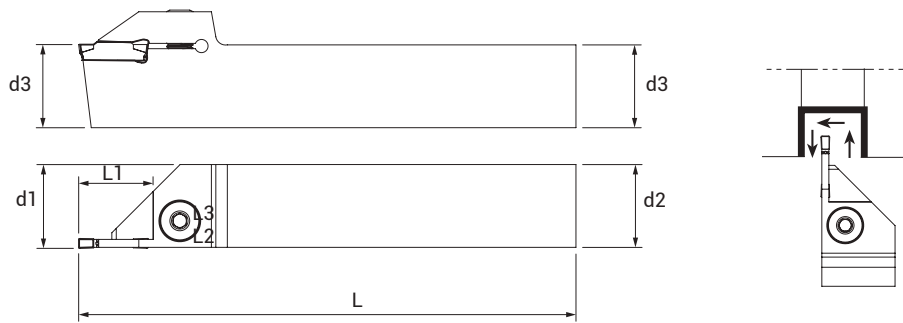

Ref.	Plaquita Insert	Ancho	d1	d2	d3	L	L1
YTER/L 2020-2T15	TD..2..	2	20,3	20	20	125	15
YTER/L 2020-2T20	TD..2..	2	20,3	20	20	125	20
YTER/L 2020-2T9	TD..2..	2	20,3	20	20	125	9
YTER/L 2525-2T17	TD..2..	2	25,3	25	25	150	17
YTER/L 2020-3T20	TD..3..	3	20,4	20	20	125	20
YTER/L 2525-3T20	TD..3..	3	25,4	25	25	150	20
YTER/L 2525-3T9	TD..3..	3	25,3	25	25	150	9
YTER/L 3232-3T20	TD..3..	3	32,4	32	32	170	20
YTER/L 2525-4T20	TD..4..	4	25,5	25	25	150	20
YTER/L 2525-3T25	TD..3..	3	35,4	25	25	150	25
YTER/L 2525-4T30	TD..4..	4	25,5	25	25	150	30
YTER/L 2525-5T25	TD..5..	5	25,5	25	25	150	25

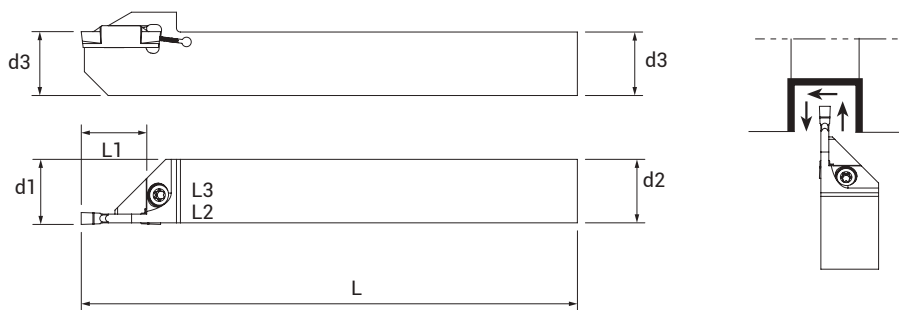

Ref.	Plaquita Insert	Ancho	d1	d2	d3	L	L1
YTER/L 1212-2T12-S	TD..2..	2	12,2	12	12	125	12
YTER/L 1616-2T16-S	TD..2..	2	16,2	16	16	125	16
YTER/L 1212-3T12-S	TD..3..	3	12,3	12	16	125	12
YTER/L 1616-3T16-S	TD..3..	3	16,3	16	16	125	16

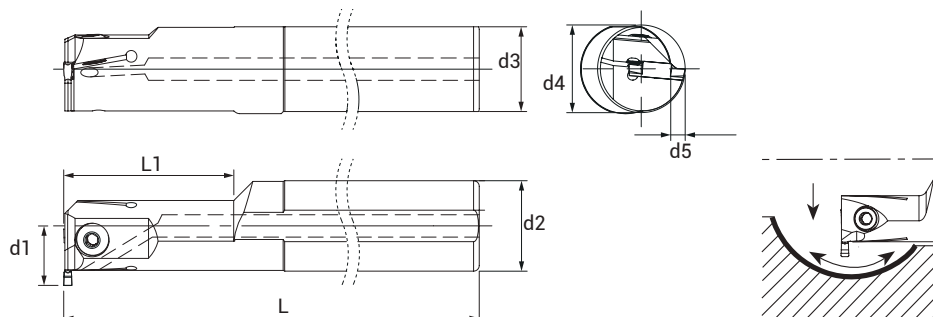

Ref.	Plaquita Insert	Ancho	d1	d2	d3	d4	d5	L	L1	Ref. Coolant
YTIR/L 16-2C-T8.5-C	TD..2..	2	16,5	16	14,8	25	8,5	150	28	●
YTIR/L 20-3C-T6-C	TD..2..	3	16	20	18,3	25	6	170	40	●
YTIR/L 25-3C-T6-C	TD..3..	3	18,5	25	23	25	6	200	40	●
YTIR/L 32-3C-T5-C	TD..3..	3	21	32	30	31	5	250	60	●

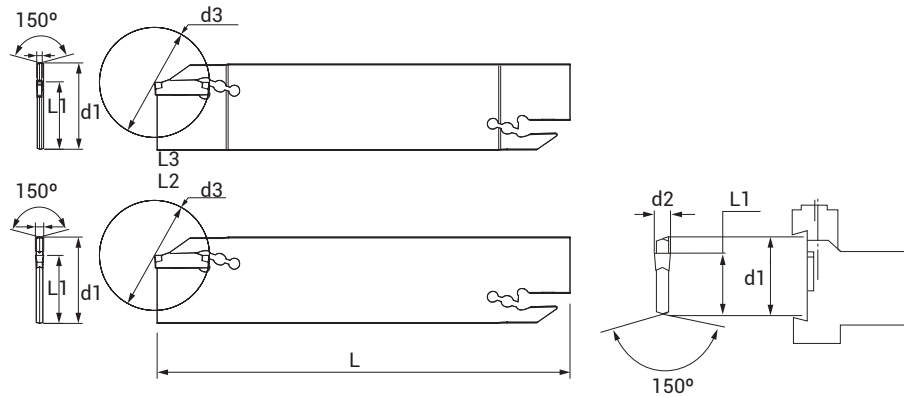

Ref.	Plaquita Insert	d1	d2	d3	L	L1
YGB 25-2	TD..2..	25	2	20	110	21,4
YGB 32-2	TD..2..	32	2	20	150	25
YGB 32-3	TD..3..	32	3	20	150	25
YGB 32-4	TD..4..	32	2	20	150	25
YGB 32-5	TD..5..	32	3	20	150	25

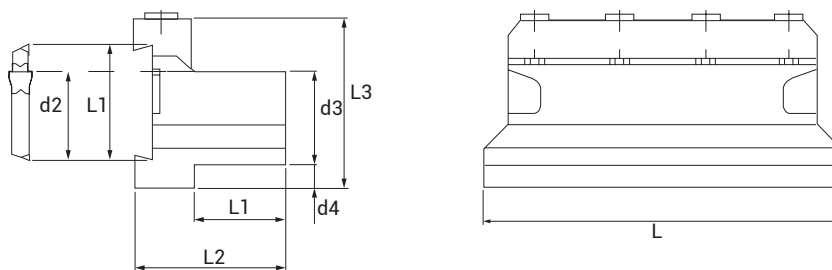

Ref.	Plaquita Insert	d1	d2	d3	d4	L	L1	L2	L3
YGBU 20-25	TD..2..	25	21,4	20	13	86	19	38	243
YGBU 25-25	TD..2..	25	21,4	25	8	110	23	42	45
YGBU 20-32	TD..3..	32	25	20	13	110	19	38	50
YGBU 25-32	TD..4..	32	25	25	8	110	23	42	50
YGBU 32-32	TD..5..	32	25	32	5	110	29	48	54